

How to check the function of the motor protection.

Artikel-Nr.: Alle Hebebühnen
Hersteller: Krömer
EAN-Code:

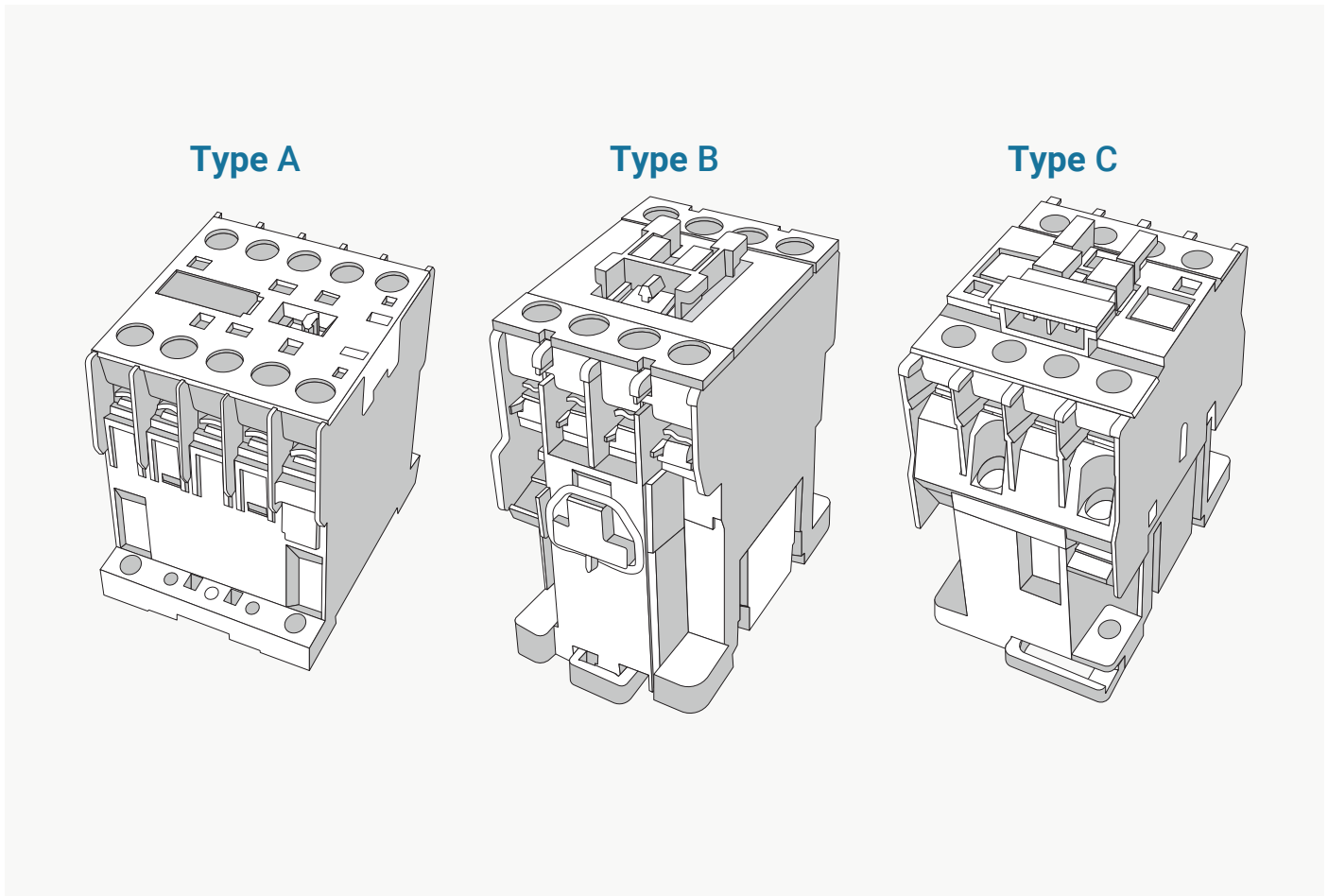

Problem: Electrical problem



Cause: Phases are not properly connected, i.e. current flow is not guaranteed.



Solution: Checking of all phases and replacement of the motor protection if necessary.

Page 2



It is essential that you disconnect the control panel from the power supply before you check the function of the motor protection!

Artikel-Nr.: Alle Hebebühnen
Hersteller: Krömer
EAN-Code:

1 Locate motor protection (type A and type B).

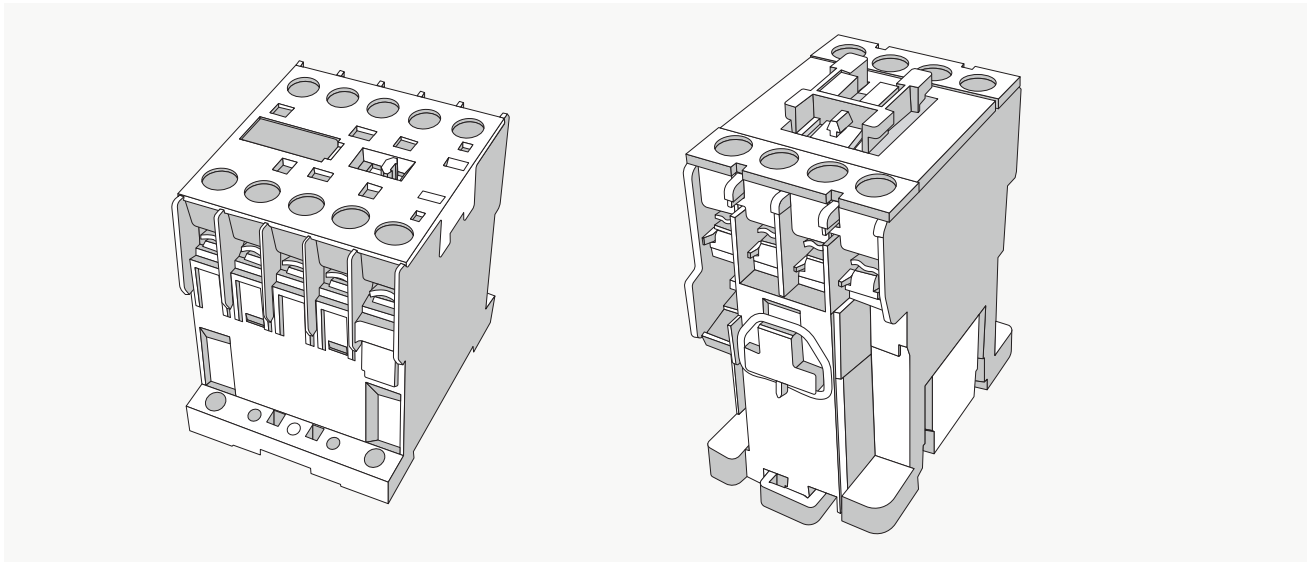

Make sure the control panel is not connected to power. Locate the motor protection on the main circuit board of the control panel, it may be necessary to unscrew the top cover for this.

2 Überprüfen der Spannung bei Motorschutz Typ A

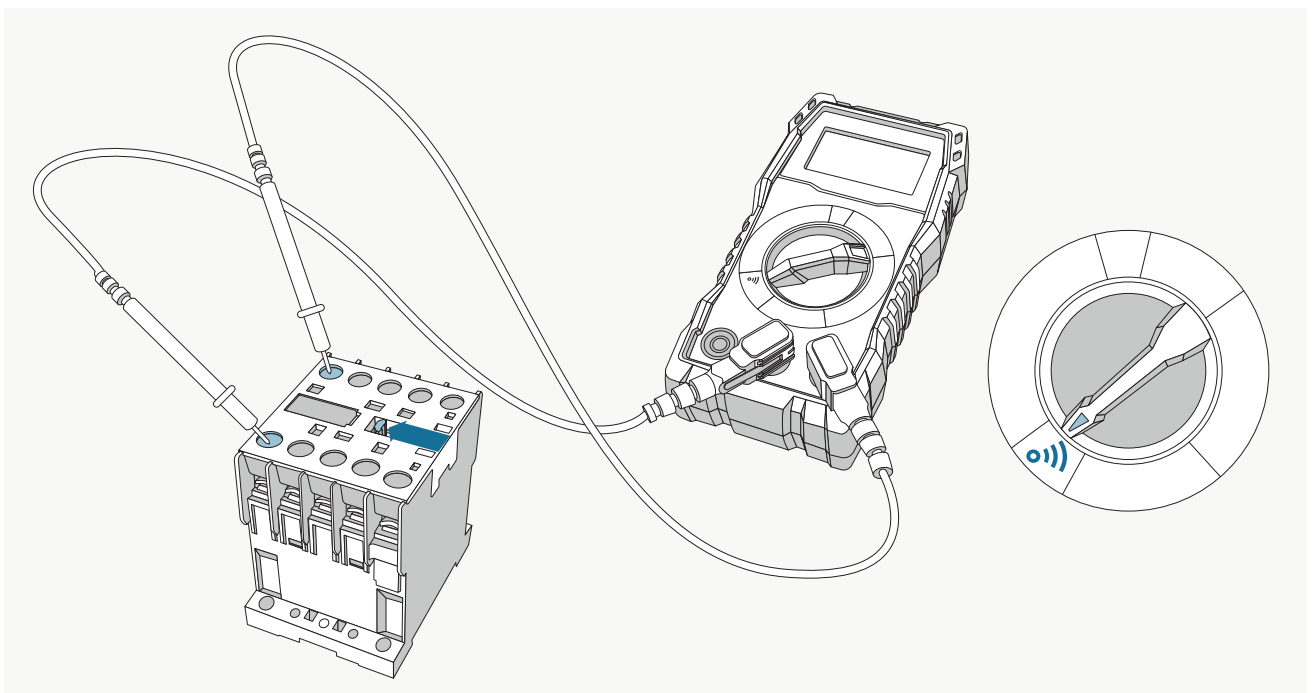

You need a multimeter to test the function. To do this, plug the diodes into the opposite phase inputs and outputs and turn on the main switch. When current passes through, a sound should be produced.



It is essential that you disconnect the control panel from the power supply before you check the function of the motor protection!

Artikel-Nr.: Alle Hebebühnen
Hersteller: Krömer
EAN-Code:

2.1 Testing the power phases (without mains power)

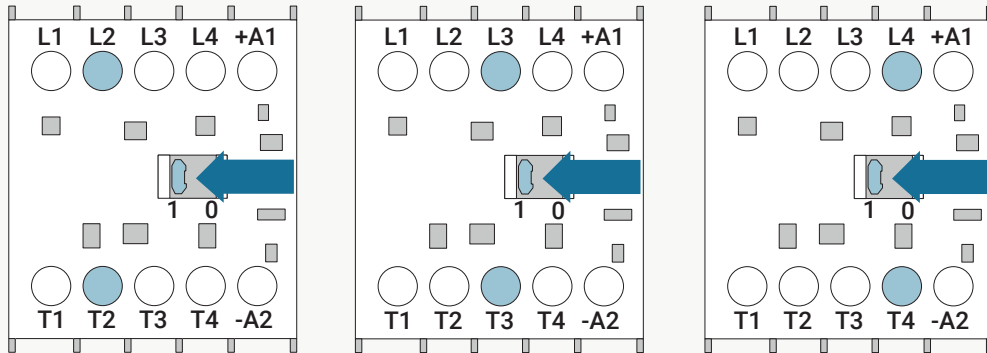

Repeat the process for all phases. Phase input is row L1 and phase output is row T1. Please do not connect the control panel to the mains at this point! If there is no tone from the multimeter on any phase, the motor protector needs to be replaced.

2 Check the voltage of the motor protection type B

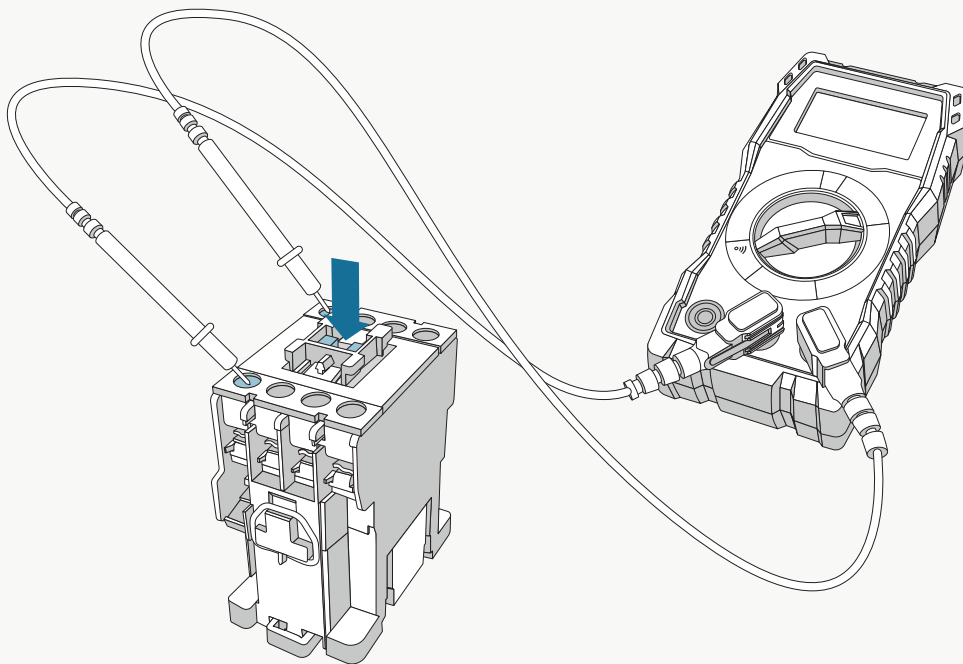

Der Motorschutz Typ B ist äußerlich etwas verschieden, funktioniert jedoch auf dieselbe Art und Weise. Stecken Sie die Dioden in die Phasein- und ausgänge. Der Hauptschalter muss hierbei nur nach unten gedrückt werden, um den Stromdurchlauf zu testen. Wiederholen Sie den Vorgang für alle Phasen. Ähnlich auch bei Motorschutz Typ C vorgehen.

Artikel-Nr.: Alle Hebebühnen
Hersteller: Krömer
EAN-Code:

3 if necessary, order a spare part

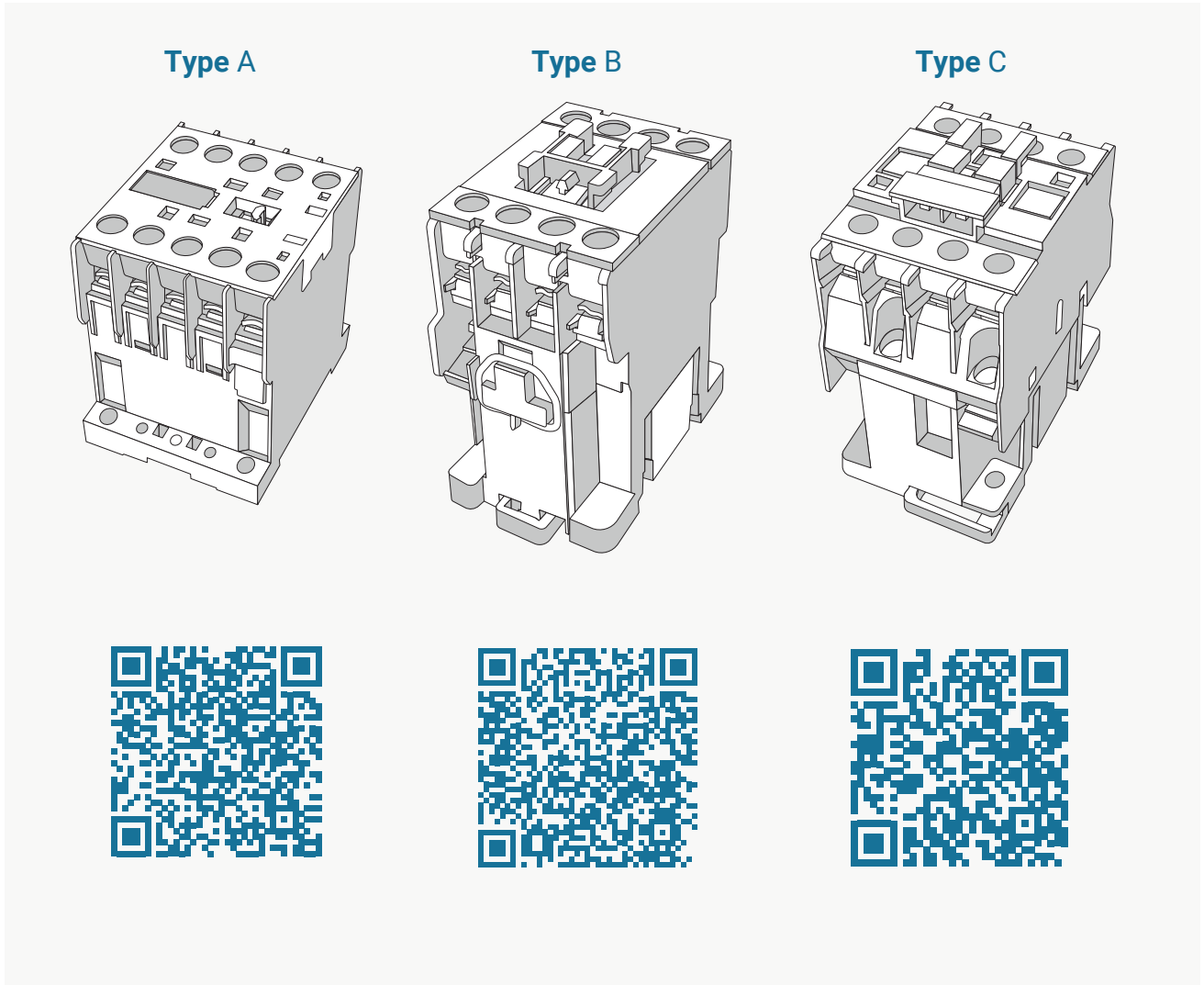

The QR codes take you directly to the respective product page.